

SPECIFICATIONS

Standard Base Models	Z-45/25J (jib)	
Height, working maximum	51 ft 6 in	15.69 m
Height, platform maximum	45 ft 6 in	13.8 m
Height, stowed maximum	6 ft 10 in	2.1 m
Horizontal reach maximum	25 ft 3 in	7.7 m
Width	7 ft 4 in	2.2 m
Length, stowed	22 ft 3 in	6.8 m
Maximum load capacity	500 lbs	227 kg
Wheelbase	6 ft 8 in	2.0 m
Turning radius (outside)	15 ft	4.5 m
Turning radius (inside)	4 ft 6 in	1.4 m
Turntable rotation (degrees)	359°	
Turntable tailswing	0 in	0 cm
Drive speed, stowed	4.8 mph 40 ft/6 sec	7.7 km/h 12.2 m/6 sec
Drive speed, booms raised	0.6 mph 40 ft/45 sec	1 km/h 12.2 m/45 sec
Airborne noise emissions Maximum sound level at normal operating workstations (A-weighted)	73 dB	
Ground clearance, center	13.25 in	33.6 cm
Ground clearance, minimum	10 in	25.4 cm
Controls	12V DC proportional	
Weight	See Serial Plate (Machine weights vary with option configurations)	
Platform dimensions, 6 foot (length x width)	72 in x 30 in	1.8 m x 76 cm
Platform leveling	self-leveling	
Platform rotation	160 degrees	

AC outlet in platform	standard	
Hydraulic pressure, maximum (boom functions)	3200 psi	221 bar
System voltage	12V	
Tire size, 4WD & 2WD RT	14-17.5 14 ply	
Gradeability, stowed, 2WD	30 %	
Gradeability, stowed, 4WD	45 %	
Fuel tank capacity	17 gallons	64.3 liters

Floor Loading Information

GVW+Rated Load	14,500 lbs	6577 kg
Axle load, maximum	11,600 lbs	5260 kg
Wheel load, maximum	7200 lbs	3265 kg
Localized pressure per tire	50 psi	3.51 kg/cm ² 345 kPa
Occupied floor pressure	199 psf	10.75 kPa

Note: Floor loading information is approximate and does not incorporate different option configurations. It should be used only with adequate safety factors.

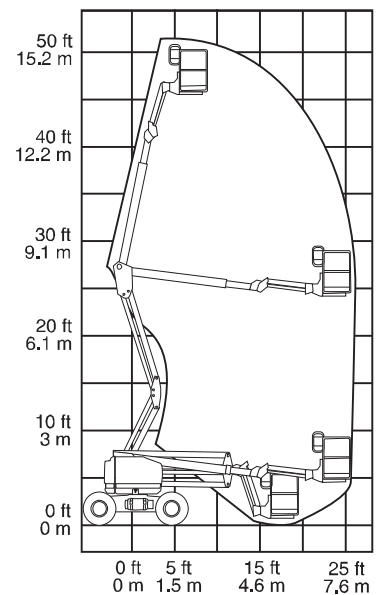

Continuous improvement of our products is a Genie policy. Product specifications are subject to change without notice or obligation.