

SELF-PROPELLED SCISSOR LIFTS

GS™-2668 DC & GS™-3268 DC



Specifications

MODELS	GS™-2668 DC		GS™-3268 DC	
MEASUREMENTS	US	Metric	US	Metric
Working height maximum*	32 ft	9.92 m	38 ft	11.75 m
A Platform height maximum	26 ft	7.92 m	32 ft	9.75 m
B Platform length - outside	8 ft 3 in	2.51 m	8 ft 3 in	2.51 m
extended	13 ft	3.96 m	13 ft	3.96 m
Slide-out platform extension deck	5 ft	1.52 m	5 ft	1.52 m
C Platform width - outside	5 ft 1 in	1.55 m	5 ft 1 in	1.55 m
Toeboard height	6 in	.15 m	6 in	.15 m
Platform height - stowed	3 ft 10.75 in	1.19 m	4 ft 3.75 in	1.31 m
D Height - stowed	7 ft 5.5 in	2.32 m	8 ft 3 in	2.45 m
rails lowered	5 ft 7 in	1.70 m	6 ft	1.83 m
E Length - stowed	8 ft 9 in	2.67 m	8 ft 9 in	2.67 m
platform extended	13 ft 5.5 in	4.10 m	13 ft 5.5 in	4.10 m
F Width	5 ft 8 in	1.73 m	5 ft 8 in	1.73 m
G Wheelbase	6 ft 1 in	1.85 m	6 ft 1 in	1.85 m
H Ground clearance - center	7.5 in	.19 m	7.5 in	.19 m

PRODUCTIVITY

Lift capacity	1,250 lbs	567 kg	1,000 lbs	454 kg
Extension deck capacity	300 lbs	136 kg	300 lbs	136 kg
Drive speed - stowed	3.0 mph	4.8 km/h	3.0 mph	4.8 km/h
Drive speed - raised	0.5 mph	0.8 km/h	0.5 mph <td 0.8 km/h	
Gradeability - stowed**	30%		25%	
Turning radius - inside	5 ft	1.52 m	5 ft	1.52 m
Turning radius - outside	12 ft 1 in	3.68 m	12 ft 1 in	3.68 m
Raise/lower speed	30/35 sec		50/37 sec	
Controls	proportional		proportional	
Drive	dual front wheel		dual front wheel	
Multiple disc brakes	dual rear wheel		dual rear wheel	
Tires - solid non-marking	9 x 21.5 in	23 x 55 cm	9 x 21.5 in	23 x 55 cm
Tires - low profile turf	12.5 x 22 in	32 x 56 cm	12.5 x 22 in	32 x 56 cm

POWER

Power source	48 V DC (eight 225 Ah batteries)		48 V DC (eight 225 Ah batteries)	
Hydraulic system capacity	9.5 gal	36 L	9.5 gal	36 L

WEIGHT***

	6,405 lbs	2,905 kg	8,010 lbs	3,633 kg
--	-----------	----------	-----------	----------

STANDARDS COMPLIANCE

ANSI A92.6, CSA B354.2, CE Compliance, AS 1418.10, PB-10-611-03

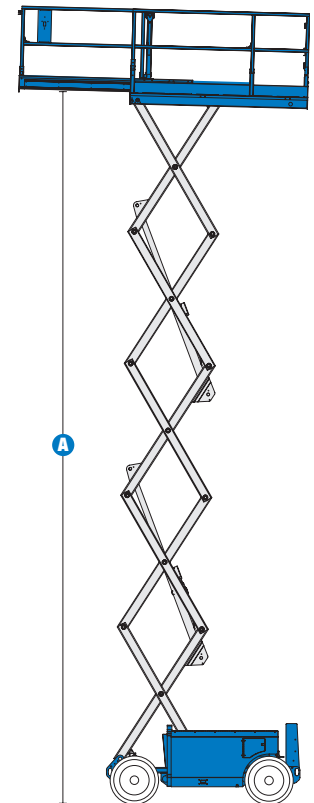
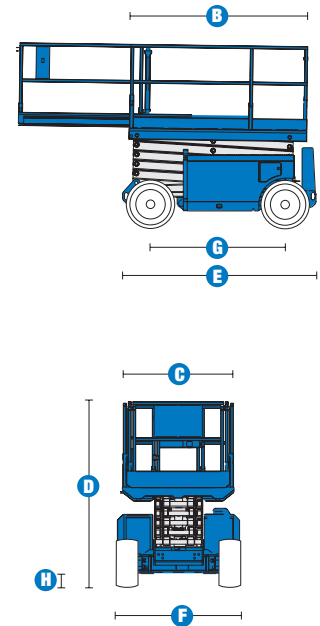

* The metric equivalent of working height adds 2 m to platform height. U.S. adds 6 ft to platform height.

** Gradeability applies to driving on slopes. See operator's manual for details regarding slope ratings.

*** Weight varies depending on options and country standards.

Features

STANDARD FEATURES

MEASUREMENTS

GS™-2668DC

- 32 ft (9.92 m) working height
- Up to 1,250 lb (567 kg) lift capacity

GS™-3268DC

- 38 ft (11.75 m) working height
- Up to 1,000 lb (454 kg) lift capacity

PRODUCTIVITY

- Steel 8 ft 3 in (2.51 m) x 5 ft 1 in (1.55 m) platform
- 5 ft (1.52 m) platform extension deck
- Folding guardrails
- 2WD
- Proportional lift and drive
- Onboard diagnostic system
- AC power to platform
- Full height swing gate
- Diamond plate deck
- Lanyard attachment points
- Manual platform lowering valve
- Dual-wheel disc brakes
- Manual brake release
- Low profile turf tires
- Tilt level sensor with audible alarm
- Descent alarm
- Electronic horn
- Hour meter

POWER

- 48V DC system
(eight 6V 225 Ah batteries)

OPTIONS & ACCESSORIES

PRODUCTIVITY

- Air line to platform
- Pipe cradle (pair)
- Solid non-marking tires
- Dual flashing beacons
- Motion alarm
- Platform work lights

POWER

- Power inverter (110V / 60 HZ)
- Power inverter (230V / 50 Hz)



Genie United States

18340 NE 76th Street
P.O. Box 97030
Redmond, Washington 98073-9730

Telephone **(425) 881-1800**
Toll Free in USA/Canada **800-536-1800**
Fax (425) 883-3475

Genie Europe

The Maltings
Wharf Road
Grantham NG31 6BH
U.K.

Telephone **+44 (0)1476 584333**
Fax +44 (0)1476 584334

Email: infoeurope@genieind.com

Distributed By:

For further information, please contact your local distributor or the Genie Industries sales office listed. Product specifications are subject to change without notice or obligation. The photographs and drawings in this brochure are for illustrative purposes only. Refer to the appropriate Operator's Manual for instructions on the proper use of this equipment. Failure to follow the appropriate Operator's Manual when using our equipment or to otherwise act irresponsibly may result in serious injury or death. Prices and specifications subject to change without notice. The only warranty applicable is the standard written warranty applicable to the particular product and sale. Genie makes no other warranty, expressed or implied. Products and services listed may be trademarks, service marks or trade-names of TEREX Corporation and/or its subsidiaries in the USA and other countries and all rights are reserved. Copyright © 2006 Genie Industries, Inc. "Genie" is a Registered Trademark of Genie Industries, Inc. in the USA and many other countries. Genie is a TEREX Company.